

Nikon Eclipse E600 N-620

Bright-Field

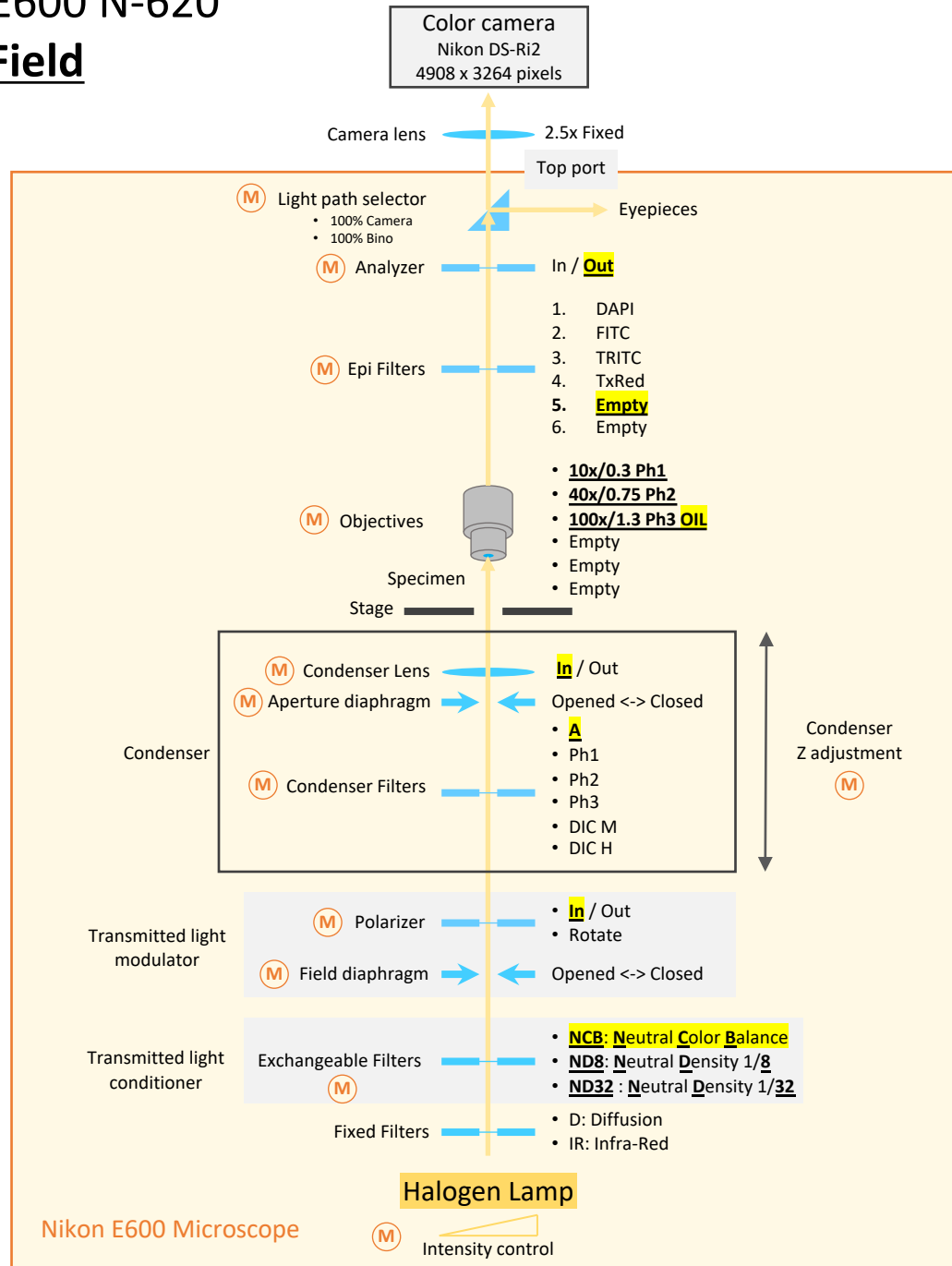

(M) Manual component

Required element

Optional element

Nikon Eclipse E600 N-620

Phase Contrast

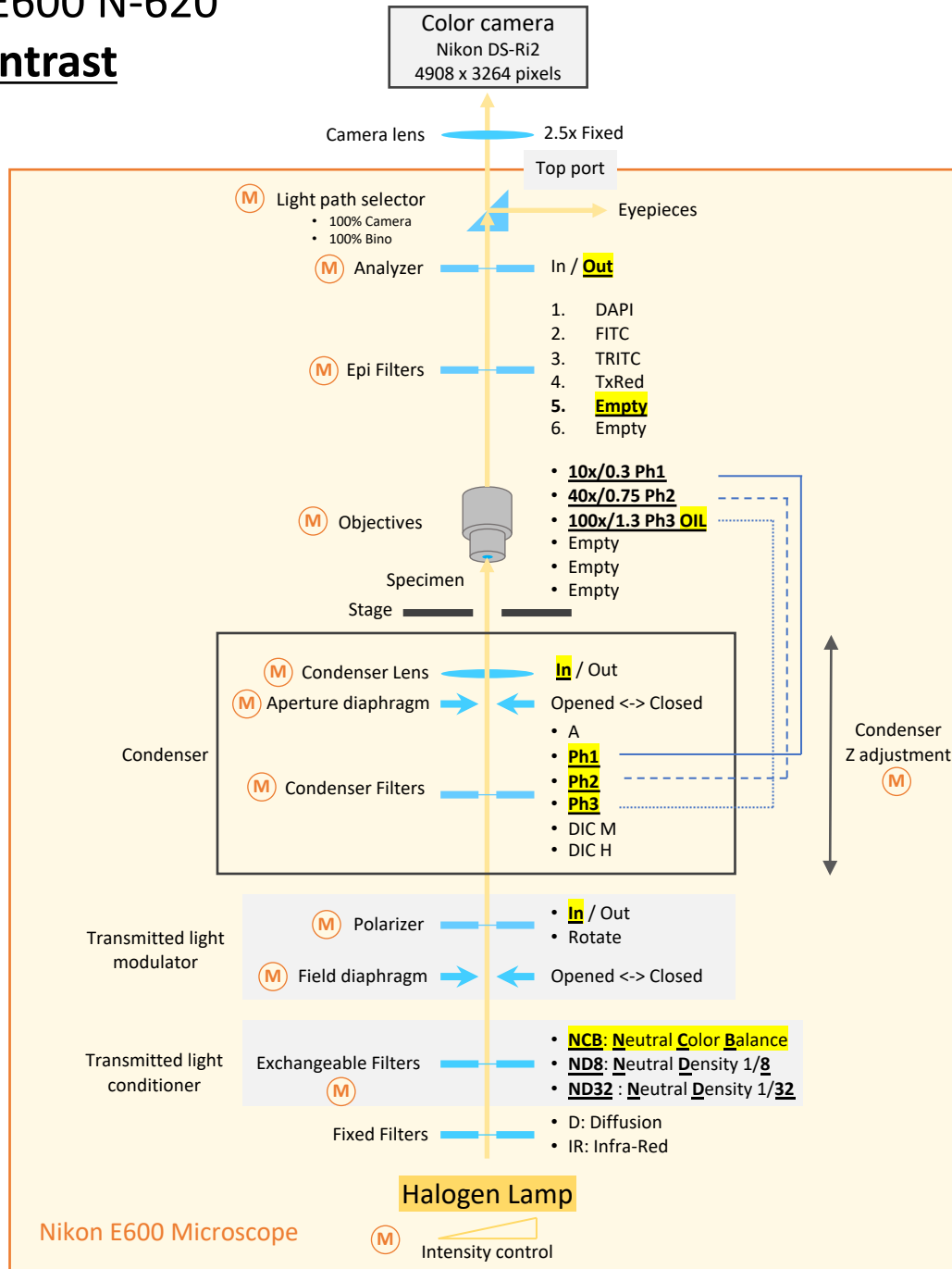

(M) Manual component

Required element

Optional element

Nikon E600 Microscope

Nikon Eclipse E600 N-620

Polarized Light

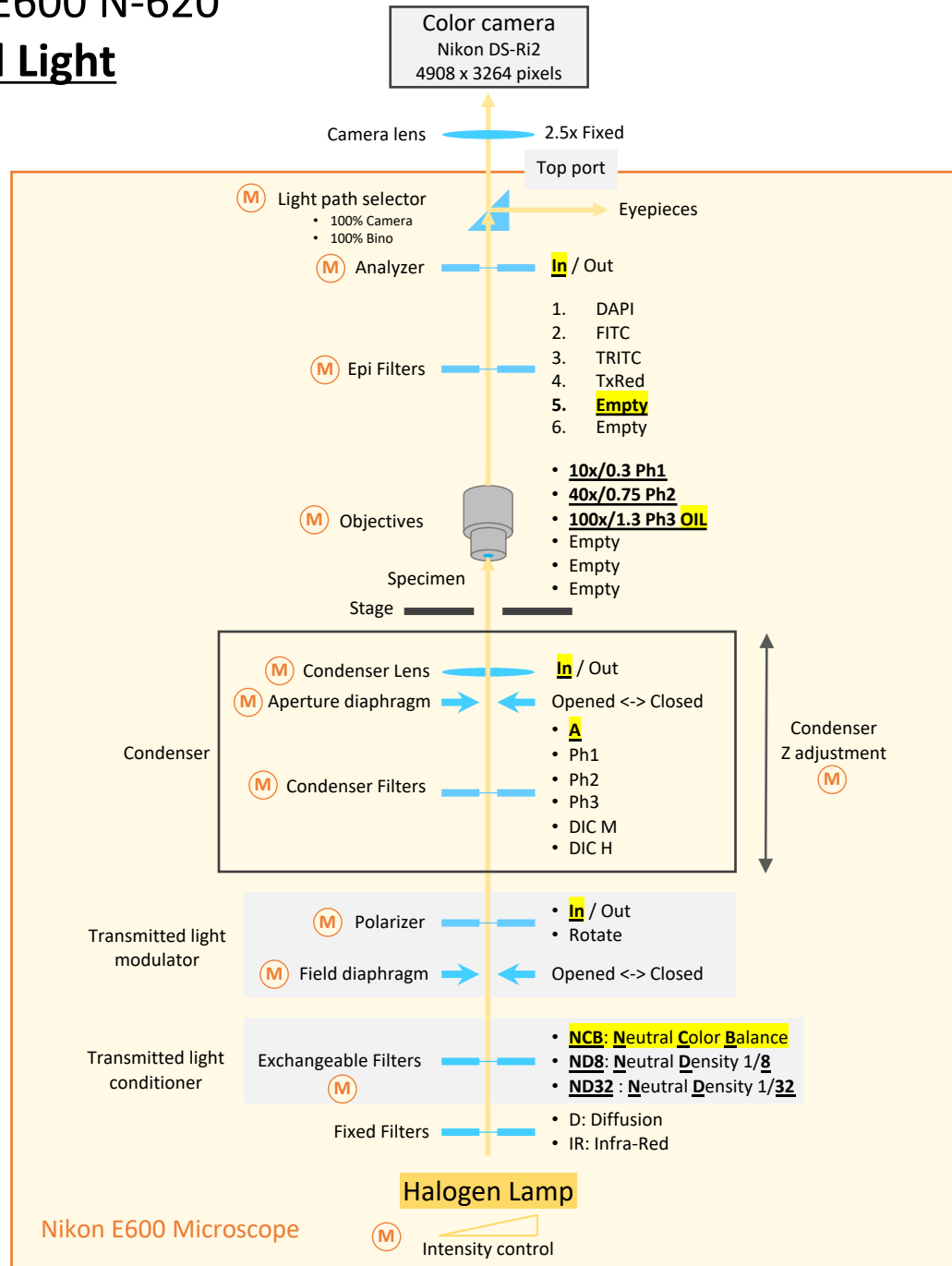

(M) Manual component

Required element

Optional element

Nikon Eclipse E600 N-620

Differential Interference Contrast

(DIC)

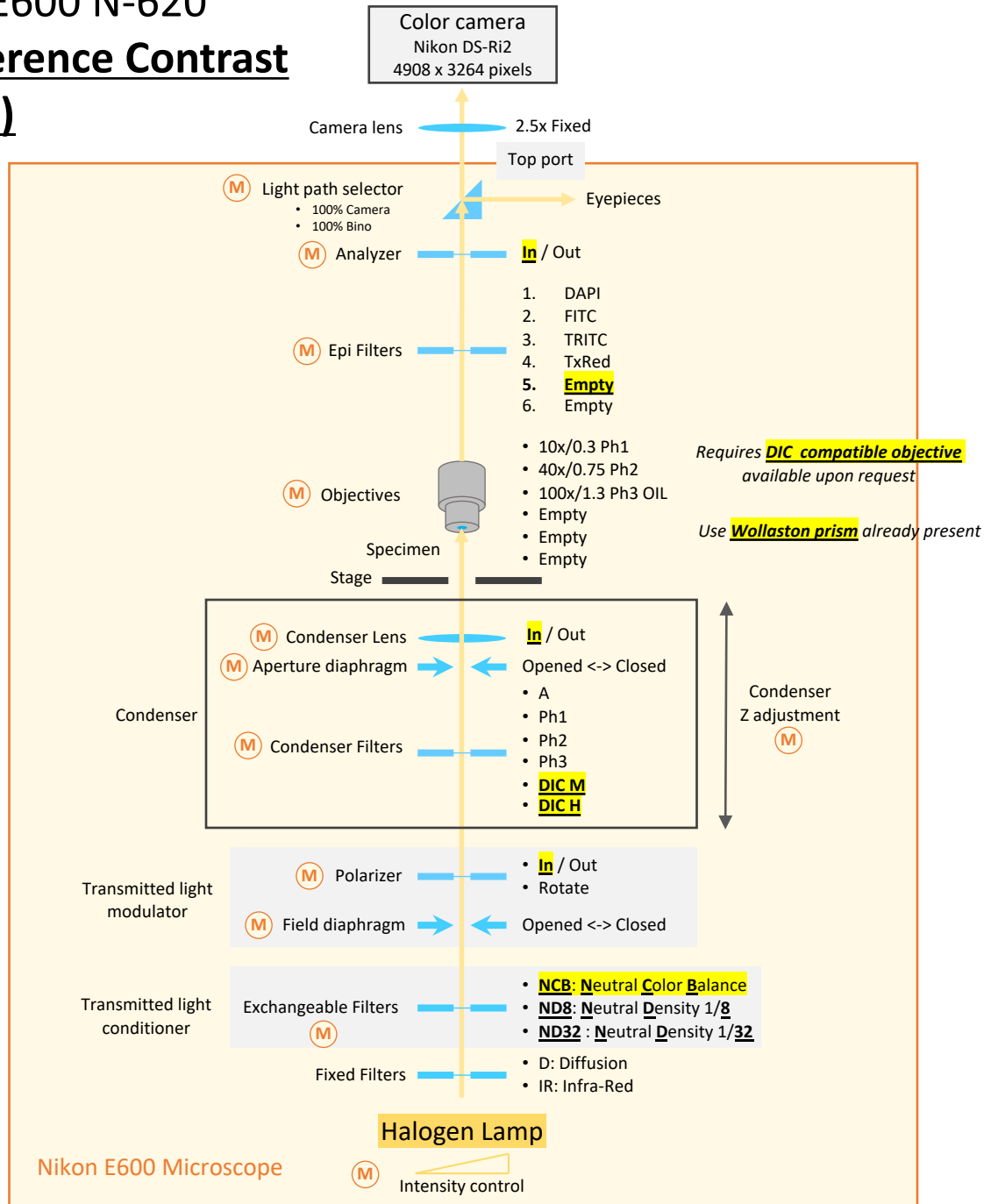

(M) Manual component

Required element

Optional element

Nikon Eclipse E600 N-620

Fluorescence

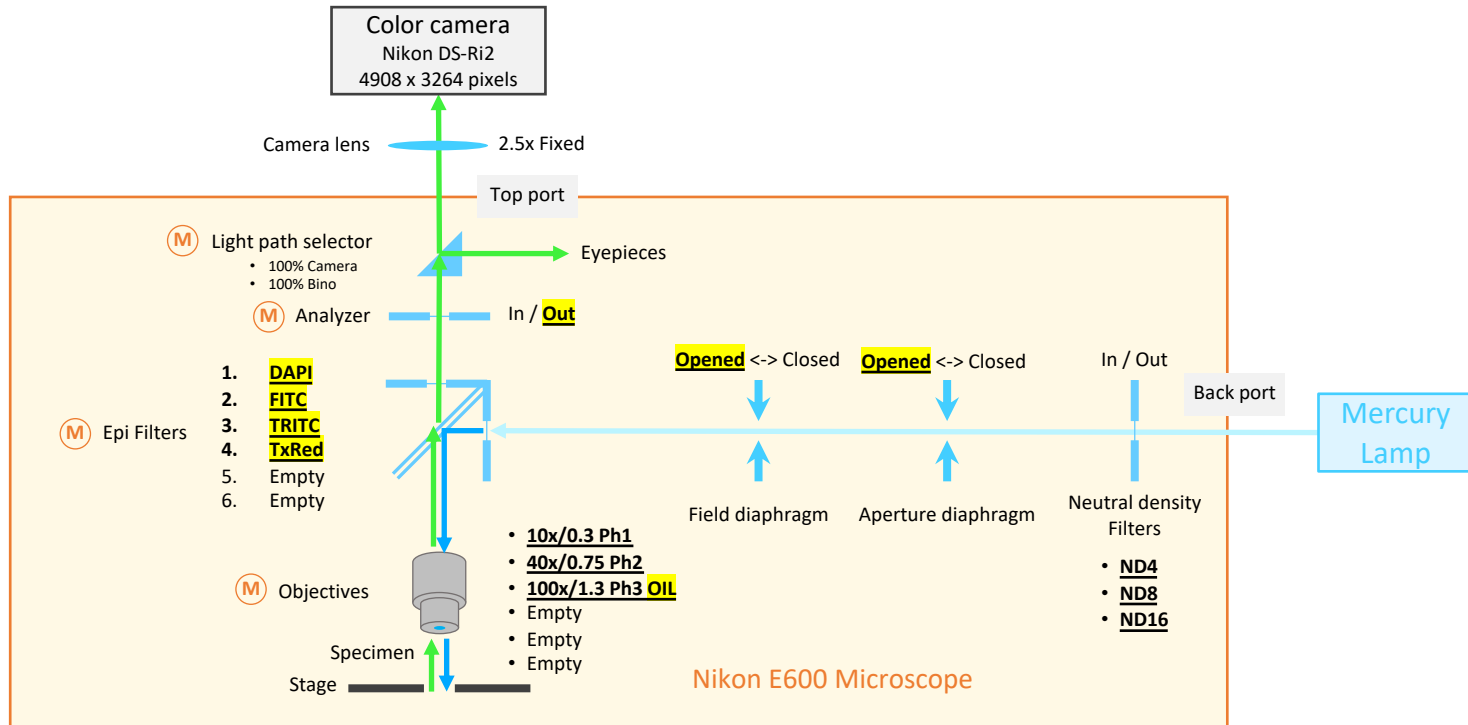

(M) Manual component

Required element

Optional element