

Nikon Ti2 R-619

Transmitted Light: Bright field

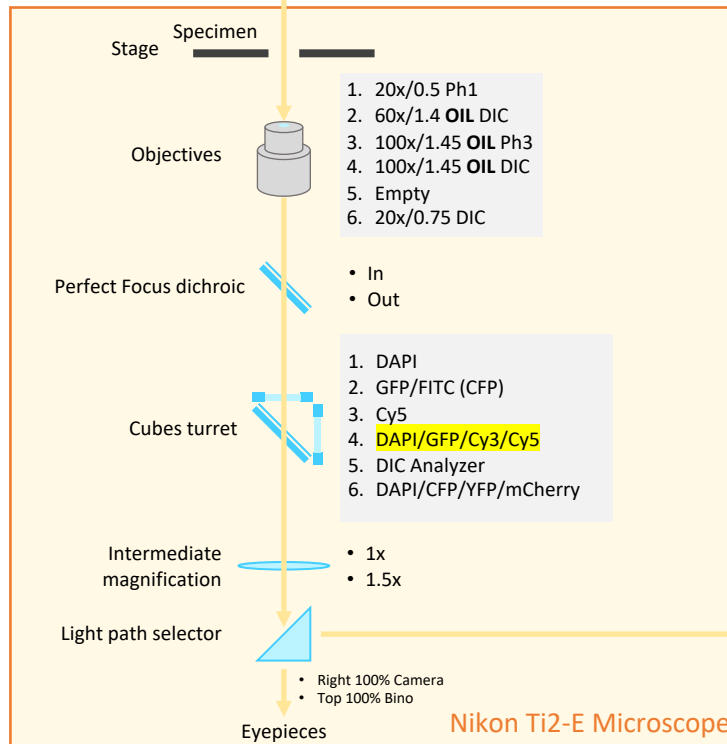
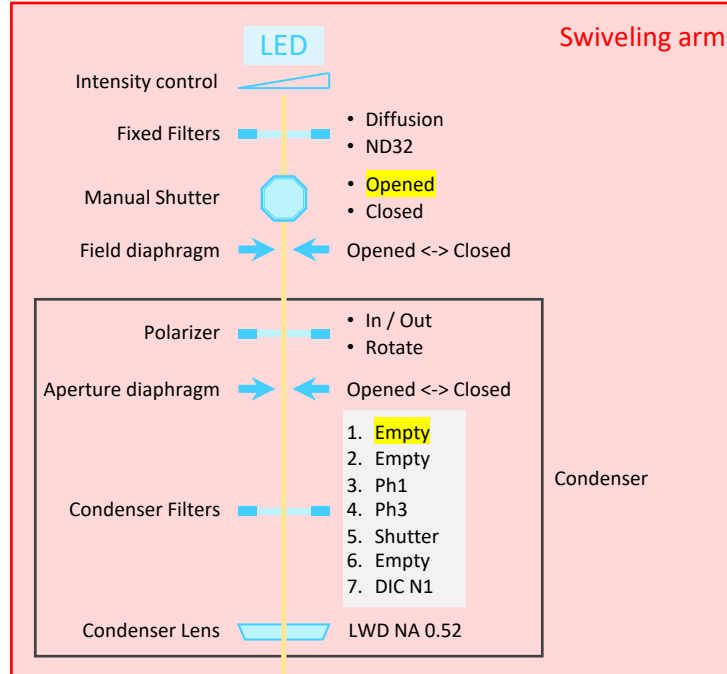

Nikon Ti2 R-619

Transmitted Light: Polarized light

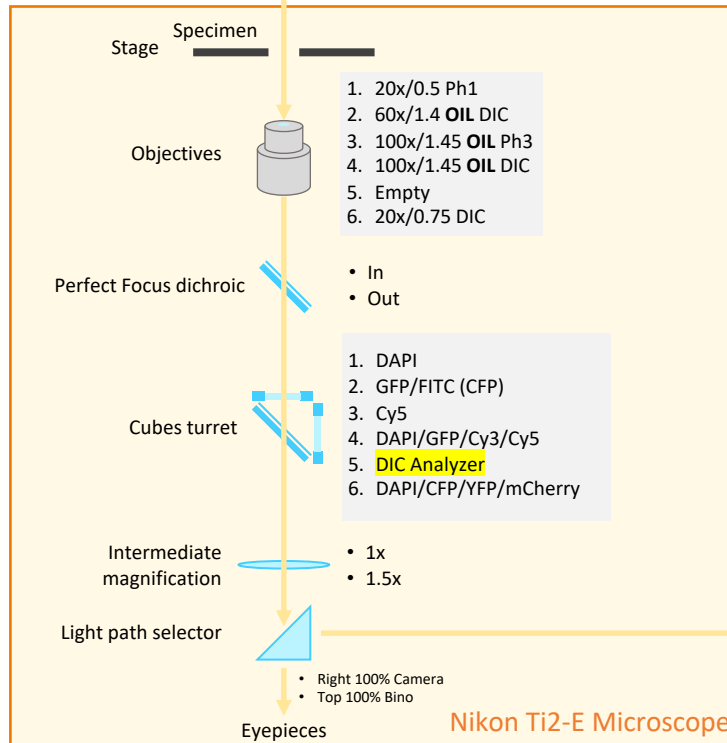
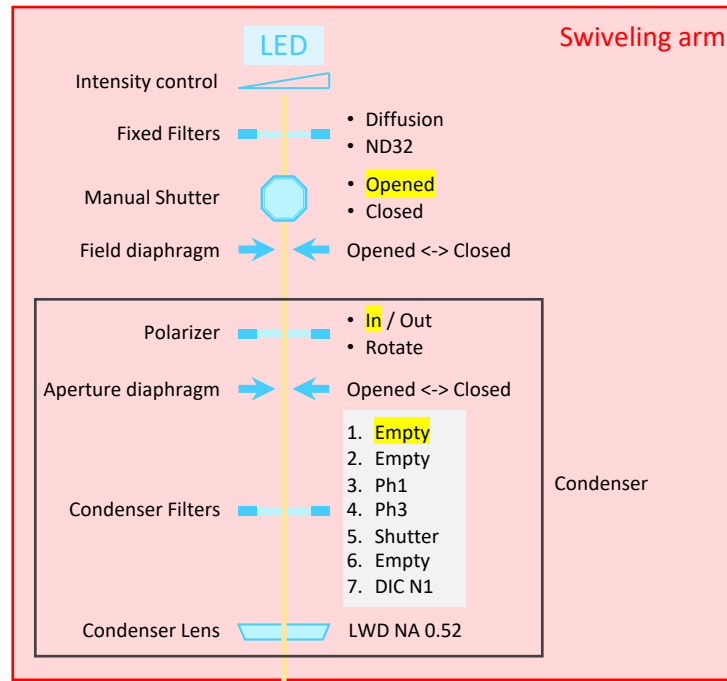

Nikon Ti2 R-619

Transmitted Light: Differential Interference Contrast (DIC)

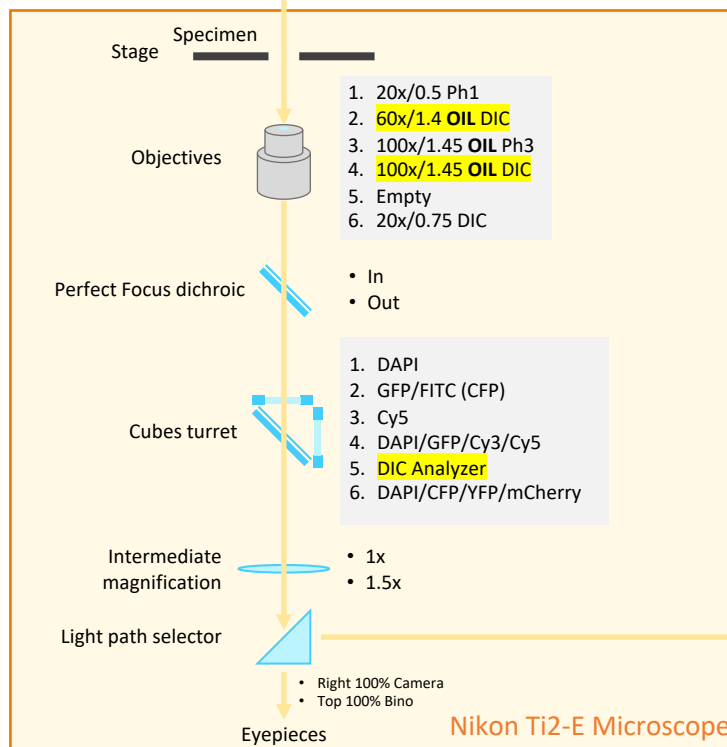
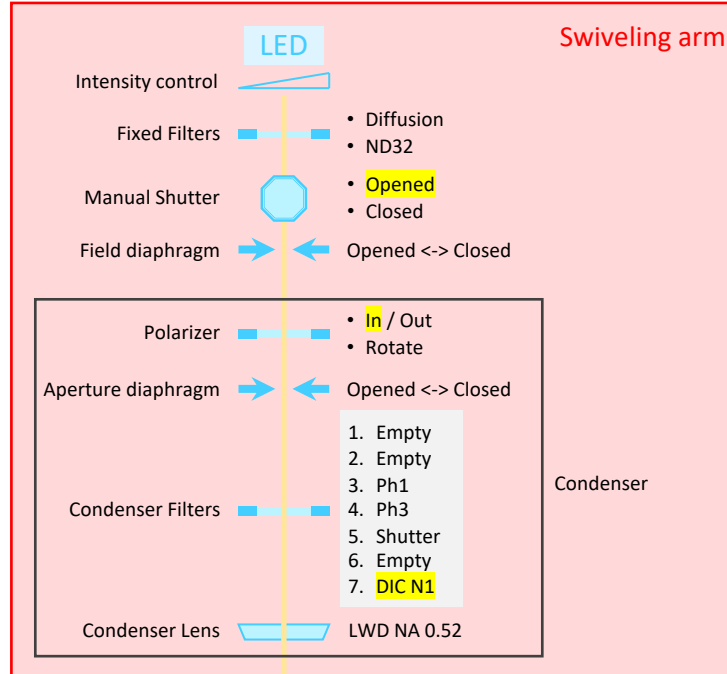

Nikon Ti2 R-619

Reflected Light: Fluorescence

