

Nikon Ti2 R-619

Transmitted Light: Bright field

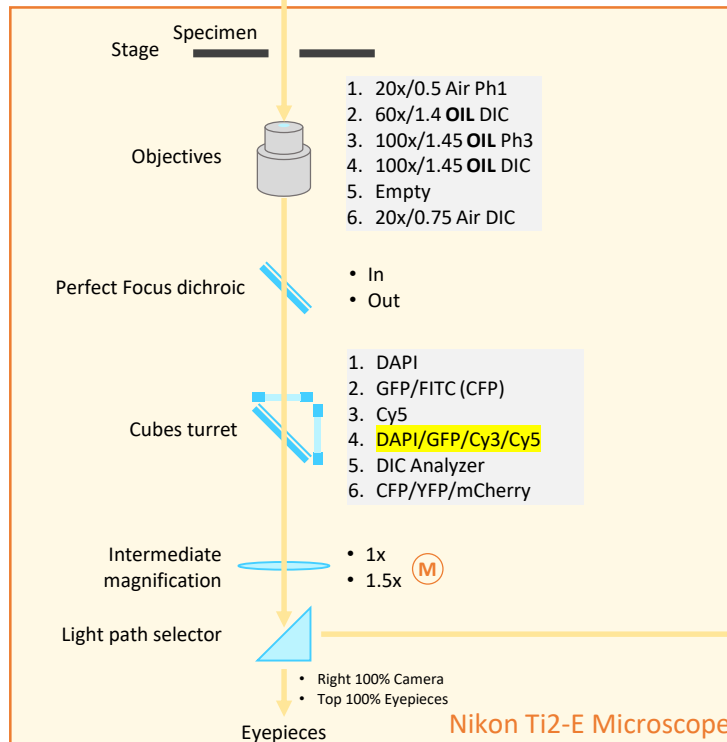
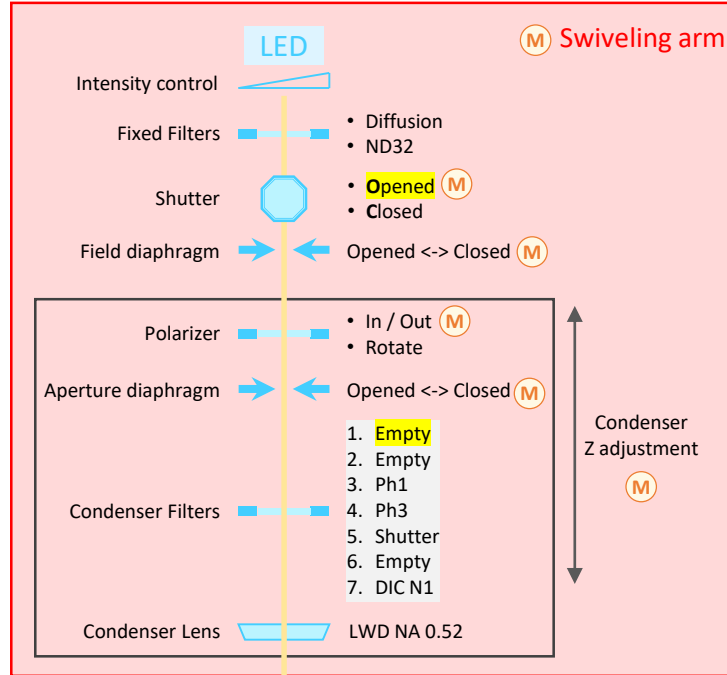

(M) Manual component

Nikon Ti2 R-619

Transmitted Light: Phase Contrast

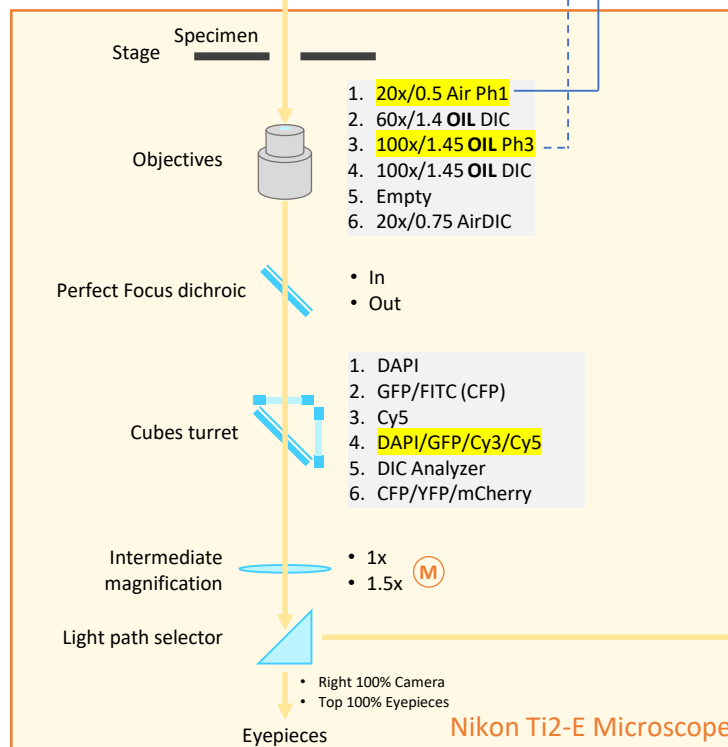
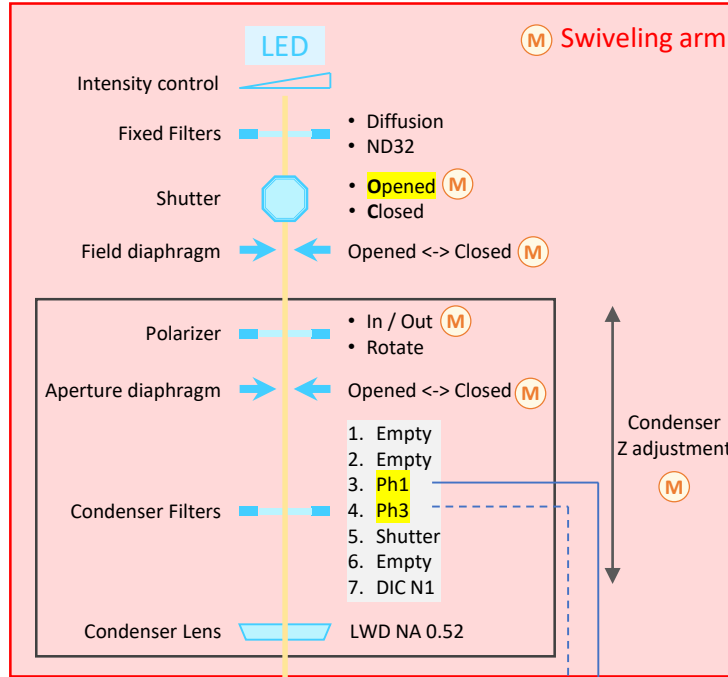

Camera
Hamamatsu ORCA Flash
2048x2048

(M) Manual component

Nikon Ti2 R-619

Transmitted Light: Polarized light

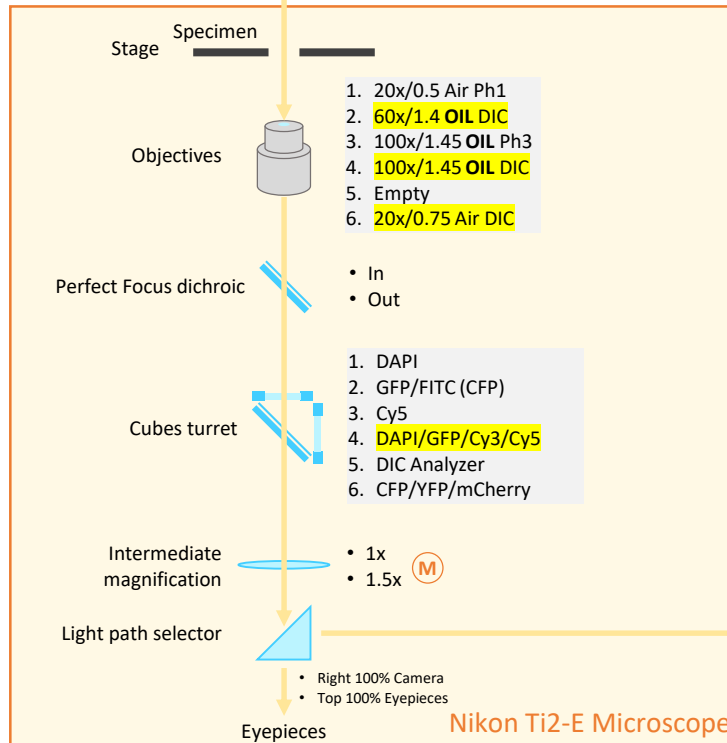
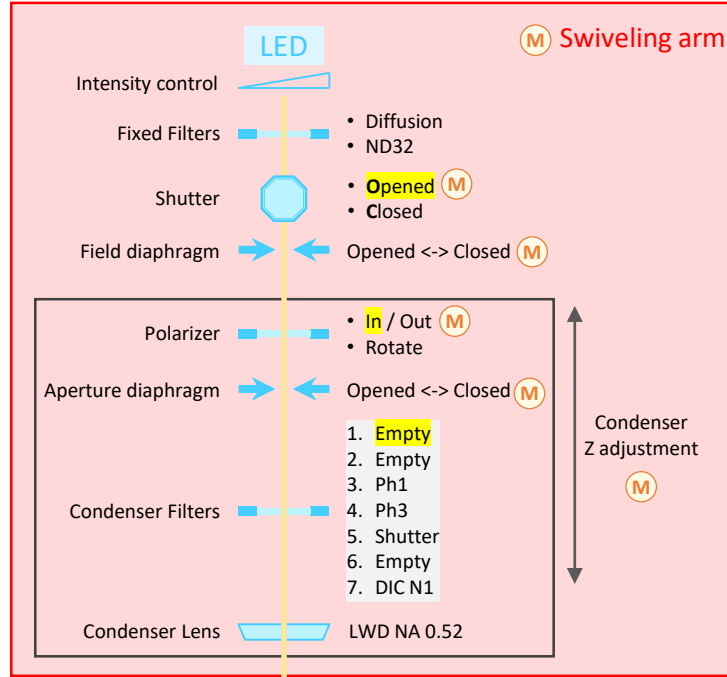

(M) Manual component

Nikon Ti2 R-619

Transmitted Light: Differential Interference Contrast (DIC)

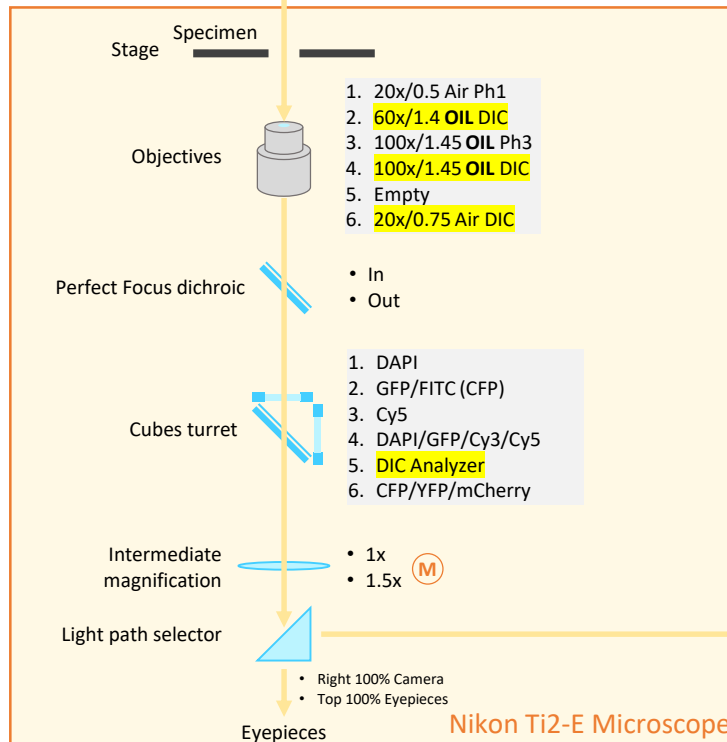
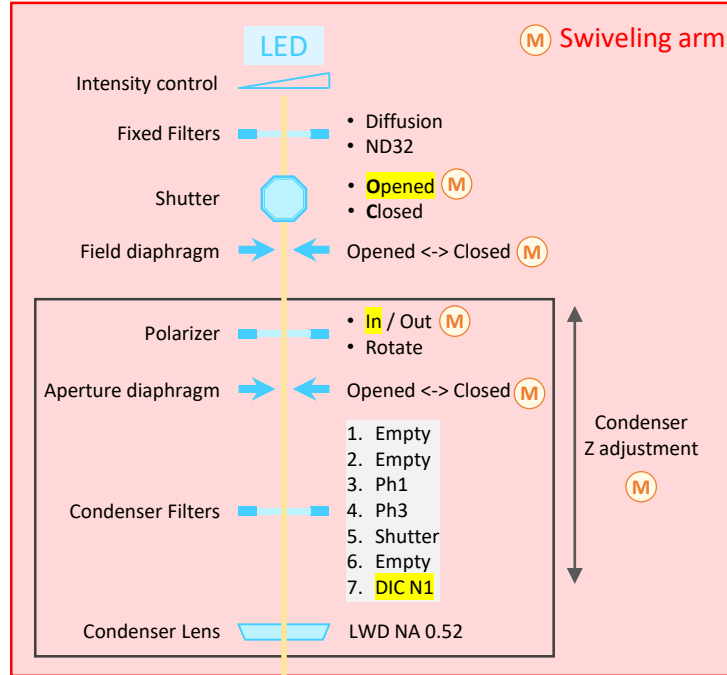

(M) Manual component

Nikon Ti2 R-619

Reflected Light: Fluorescence

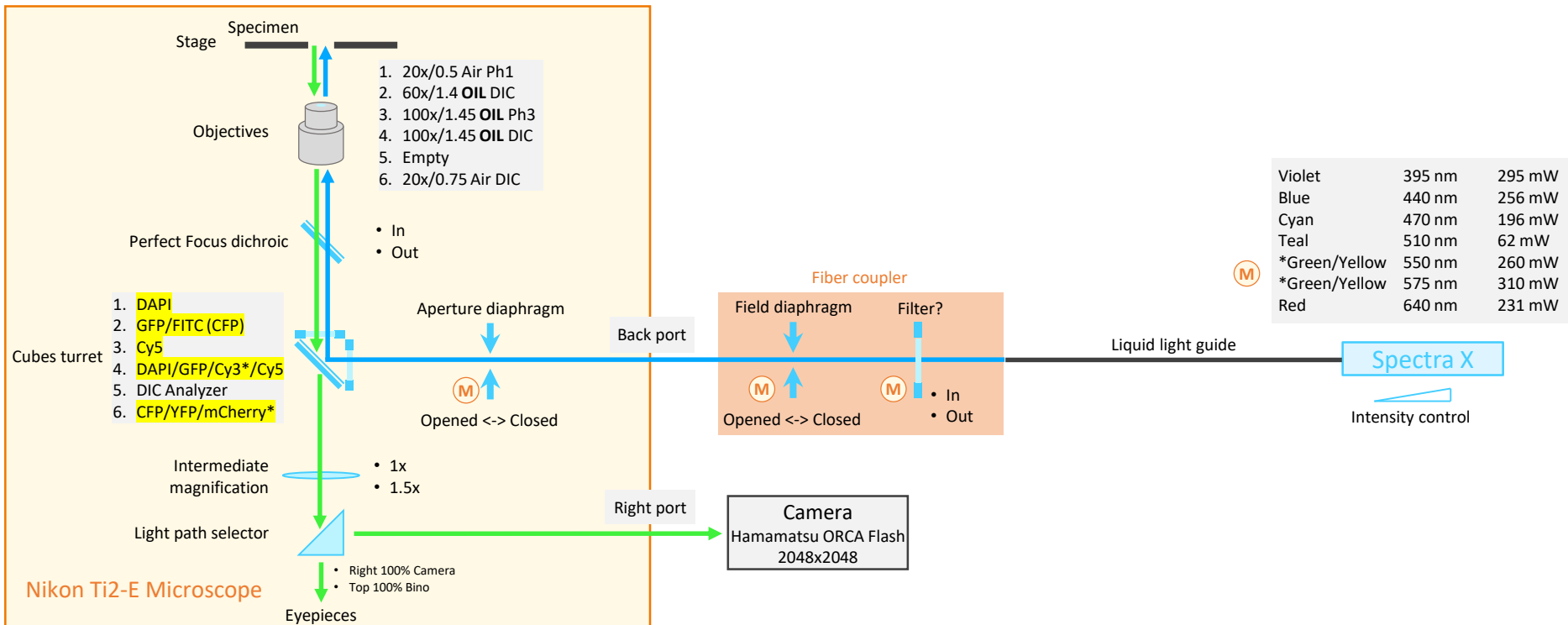

(M) Manual component

(M)*:requires manual filter switching