

Features & benefits

EMCCD Technology

Ultimate in Sensitivity from EMCCD gain – even single photon signals are amplified above the noise floor. Full QE of CCD chip is harnessed (no intensifier).

TE cooling to -95°C

Unparalleled elimination of EM-amplified darkcurrent noise.

RealGain™

Absolute EMCCD gain selectable directly from a linear and quantitative scale.

iCam

Unique innovation that empowers the EMCCD to operate with market-leading acquisition efficiency through live cell microscopy software.

> 65% QE from virtual phase sensor

Highly efficient photon collection. One window design.

Extended red response

Significantly higher sensitivity to red-emitting dyes such as CY5, mCherry, dsRed and Alexa680. Bose Einstein Condensation in NIR.

Fast speed readout

35MHz readout speed delivers 31 frames/sec at full megapixel resolution; 60 frames/sec when 2x2 binned.

UltraVac™*1

Critical for sustained vacuum integrity and to maintain unequalled cooling and QE performance, year after year.

8 x 8 μm pixel size (fully binnable)

Excellent balance of NyQuist resolution and photon collection.

Minimal Clock-Induced Charge

Unique pixel clocking parameters, yielding minimized spurious noise floor.

Enhanced Baseline Clamp

Essential for quantitative accuracy of dynamic measurements.

Negligible EM Gain ageing

No requirement for gain recalibration.

Built-in C-mount compatible shutter (optional)

Easy means to record control dark images – excellent for optimization of experimental set-up.

Cropped sensor mode

Specialised acquisition mode for continuous imaging with fast temporal resolution.

“ High resolution Megapixel EMCCD ”

A proud member of Andor's iXon^{EM}+ EMCCD range, the 885 benefits from the unique innovations and high-end performance specifications that have characterized this camera family as the industry's leading high-performance EMCCD.

The megapixel sensor format and 8 x 8μm pixel size of the 885 presents an attractive combination of field of view and resolution, offering excellent Nyquist over-sampling for cell microscopy.



When more light is available from the sample, the EMCCD gain can be completely switched off and the camera operated as a 'traditional' CCD camera. However if the camera is used in low-light conditions, the EMCCD gain can be applied to render it single photon sensitive, while maintaining a full resolution frame rate of 31 frames/sec. The absolute EM gain multiplication can be varied linearly from unity up to a thousand times directly via RealGain™, a true quantitative EM gain scale. Extended red QE response is ideally matched to popular red-emitting fluorophores and for imaging of Bose Einstein Condensates using NIR probe laser

Camera overview

Active Pixels	1004 x 1002
Pixel Size (W x H; μm)	8 x 8
Image Area (mm)	8 x 8
Active Area Pixel Well Depth (e ⁻ , typical)	30000
Gain Register pixel well depth (e ⁻ , typical)	80000
Max Readout Rate (MHz)	35
Frame Rate (frames per sec)	
Full resolution	31.4
2 x 2 binning	60.5
Read Noise (e ⁻)	
@ 35 MHz	25
with EM Gain	<1

Quantum efficiency*2

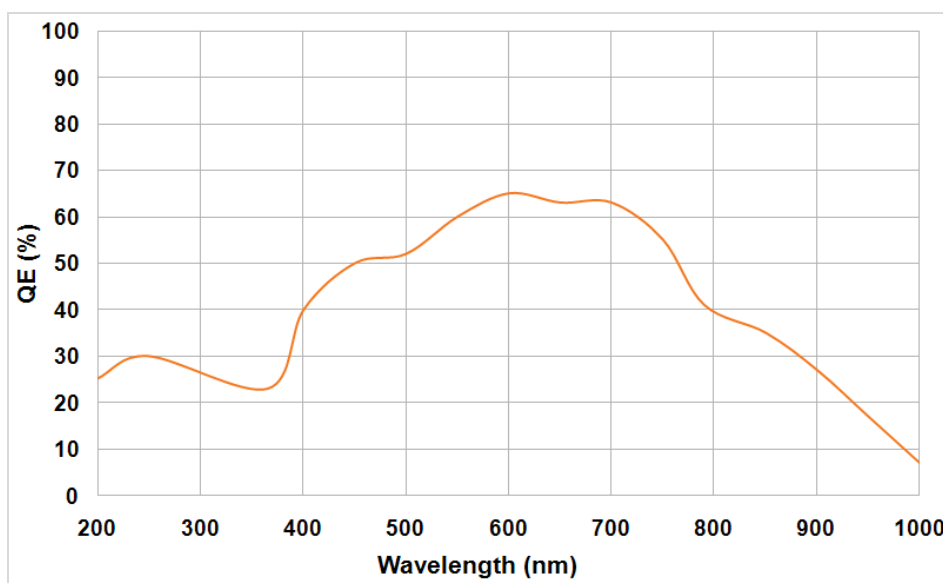

Peak Quantum Efficiency

CCD Type	Typical
VP @ 600nm	65%

Technical specifications

System characteristics

Pixel Readout Rate (MHz)	35, 27, 13
Linearity (% , maximum)^{*3}	1
Vertical Clock Speed (µs)	0.5 to 1.9 (variable)
Electron Multiplier Gain	1 - 1000 times (software controlled) via RealGain™ control with temperature compensation
Digitization	14-bit @ 35, 27 & 13 MHz readout rate
Dark Current (e⁻/pix/sec)^{*4}	
@ -70°C	0.028
@ -85°C	0.012
@ -95°C	0.005

System Readout Noise (e⁻)^{*5}

	Typical	With Electron Multiplication
35MHz through EMCCD amplifier	25	<1
27MHz through EMCCD amplifier	22	<1
13MHz through EMCCD amplifier	12	<1

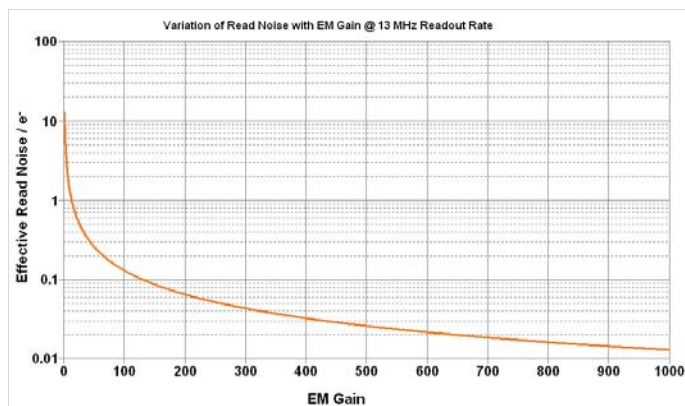

Minimum sensor temperatures (typical)^{*6}

	DV option	DU option
Air cooled (ambient air at 20°C)	-70°C	-80°C
Re-circulator (XW-RECR); (ambient air @ 20°C)	-80°C	-90°C
Water-cooled (@ 10 °C, 0.75 l / min)	-85°C	-95°C

Operating & storage conditions

Operating Temperature	0°C to 30°C ambient
Relative Humidity	< 70% (non-condensing)
Storage Temperature	-25°C to 55°C

Power requirements^{*7}

- 1A @ +12V
- 0.3A @ -12V
- 3.0A @ +5V

Full frame rate^{*8}

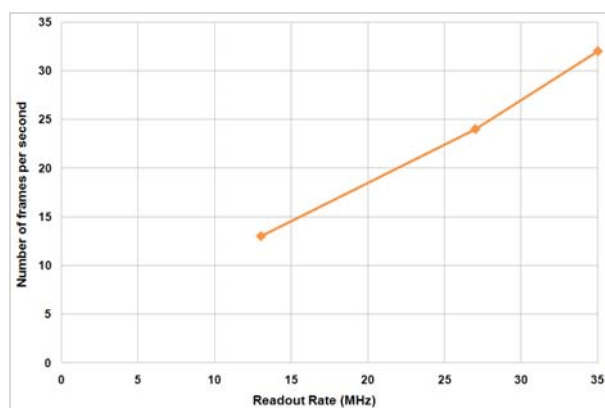

Max frames per second^{*9}

Binning	Array size			
	1002 x 1002 (Full Frame)	512 x 512	256 x 256	128 x 128
1 x 1	31.4	60.3	113	213.7
2 x 2	60.5	113.6	201.6	367.7
4 x 4	112.6	204.1	331.0	568.2

Computer requirements

Minimum

- Windows 2000 or XP operating system
- PCI 2.2 or PCI-X 1.0 compatible computer (PCI slot must have bus master capability)
- Available auxiliary internal power connector
- 25 MBytes free hard disc space

Recommended

- 3.2 GHz Pentium (or better) + 1 GB RAM
- SATA RAID 0 hard disc, e.g. Seagate Barracuda, Western Digital Caviar RE or Raptor, etc.

NOTE: In all cases the operating system should be on a separate hard drive and the hardware controller should be on a separate PCI bus

Need more information? Please contact us at:

International Office	US Office
Phone: +44 28 9023 7126	Phone: 800.296.1579
Fax: +44 28 9031 0792	Fax: 860.290.9566
Japanese Office	Chinese Office
Phone: +81 3 3511 0659	Phone: +86-10-5129-4977
Fax: +81 3 3511 0662	Fax: +86-10-6445-5401

Ordering information & notes

To order the camera you require, please use the following ordering system:

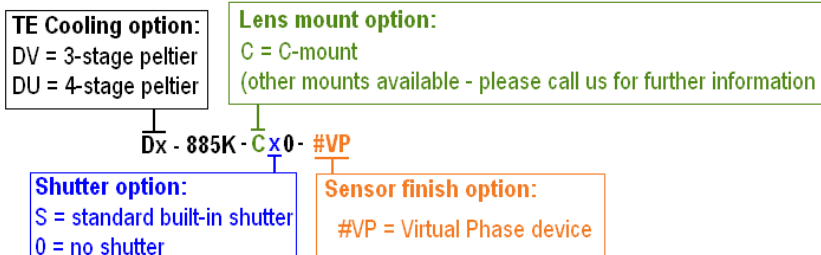

E.g. a DV-885K-C00-#VP is an iXon^{EM}+ 885 camera with 3-stage peltier vacuum cooling and without internal shutter.

The iXon^{EM}+ 885 also requires one of the following software options:

Andor Solis (i)	A ready-to-run Windows 2000 or XP-based package with rich functionality for data acquisition and processing.
Andor SDK	A DLL driver and software development kit that let you create your own applications for the Andor Camera. Available for Windows 2000 or XP and Linux.
Andor iQ	A comprehensive multi-dimensional imaging software package. Offers tight synchronization of EMCCD with a comprehensive range of microscopy hardware, along with comprehensive rendering and analysis functionality. Modular architecture for best price/performance package on the market.
Third party software compatibility	Drivers are available so that the iXon ^{EM} + range can be operated through a large variety of third party imaging packages.

The following accessories are available for use with the iXon^{EM}+ 885:

XW-RECR	Re-circulator for enhanced cooling performance
XW-CHIL-150	Chiller/re-circulator for maximum cooling performance

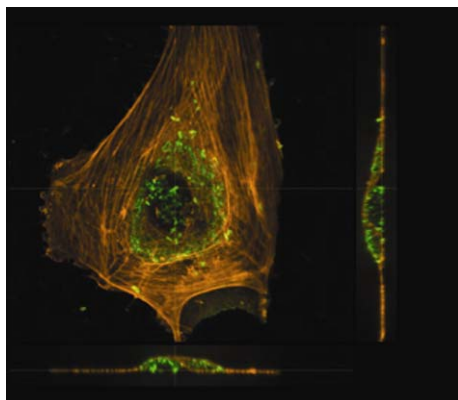

Image of Human Umbilical Vein Endothelial Cells (HUVEC) taken with an iXon^{EM}+ 885.

Courtesy of Christophe Dehio and Matthias Truttmann, University of Basel.

Specifications are subject to change without notice

- ◆1 Assembled in a state-of-the-art Class 10,000 cleanroom facility, Andor's UltraVac™ vacuum process combines a permanent hermetic vacuum seal (no o-rings), with a stringent protocol to minimize outgassing, including use of proprietary materials. Outgassing is the release of trapped gases that would otherwise prove highly problematic for high-vacuum systems.
- ◆2 Quantum efficiency of the CCD sensor as measured by the CCD Manufacturer.
- ◆3 Linearity is measured from a plot of Counts vs. Signal up to the saturation point of the system. Linearity is expressed as a percentage deviation from a straight line fit.
- ◆4 The dark current measurement is averaged over the CCD area excluding any regions of blemishes.
- ◆5 System Readout noise is for the entire system. It is a combination of CCD readout noise and A/D noise. Measurement is for Single Pixel readout with the CCD at a temperature of -75°C and minimum exposure time under dark conditions. Under Electron Multiplying conditions, the effective system readout noise is reduced to sub 1e⁻ levels. Noise values will change with pre-amplifier gain (PAG) selection. Values quoted are measured with highest available PAG setting.
- ◆6 The iXon^{EM}+ 885 can be ordered either with 3-stage or 4-stage peltier vacuum cooling, the 'DV' or 'DU' options respectively.
- ◆7 These power requirements are the maximum load that will be drawn from the computer for the camera head and controller card combined.
- ◆8 The graph shows the full frame rates possible when reading out the sensor at 35, 27 and 13 MHz pixel readout rates, and using 0.5µs per row vertical clock speed.
- ◆9 The max frames / second for iXon^{EM}+ imaging CCDs is the maximum speed at which the device can acquire images in a standard system. Shown are the frame rates at 35 MHz digitization rates for a range of binning or array size combinations. Measurements are shown for 0.5µs per row vertical clock speed. It also assumes internal trigger mode of operation.

Dimensions

Weight: 3.4 kg [7.5 lb]

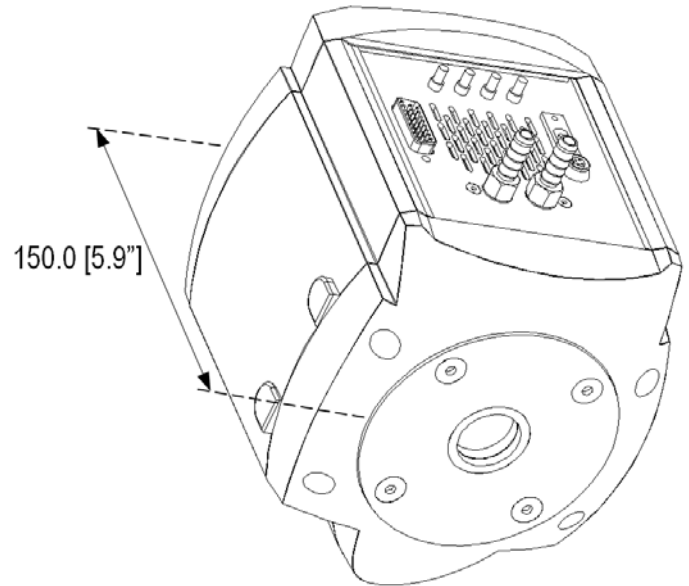
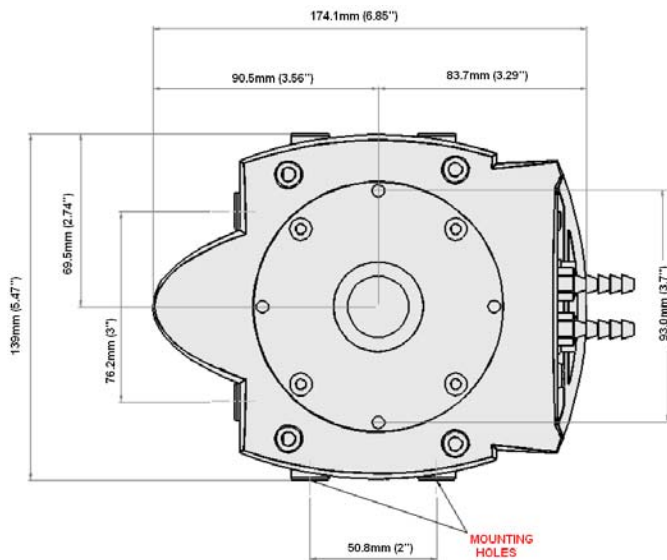

Notes:

1. The clearance from the C-mount face plate to the shutter is 6mm. Please ensure that when fitting a lens, to a system with a built in shutter, that it does not extend into the housing by more than 5mm.
2. There are mounting holes (1/4-20UNC) located on three sides of the camera. They are positioned centrally at a distance of 40mm from the front of the front face.

Connections

